

Advanced compaction for a cleaner environment

TT1100E bin compactors

The industry-leading TT1100E compacts waste directly into most standard four wheeled bins. This reduces waste volumes by approximately 75%, cutting waste management costs.

Combining the simplest of form with the most practical of function, the TT1100E is easy to use and provides both environmental and financial benefits to restaurants, pubs, hotels, factories, bakeries, office blocks, prisons and hospitals.

Key Features

- Simple functional design
- Designed for internal and external use
- Compacts into standard 660 - 1280 litre bins
- Eliminates all problems associated with open bins
- Compacts approximately 3 or 4 bin loads into one
- Improves control and reduces costs
- Control panel on either side



Total Waste Handling Solutions
for a Better Environment

Technical Specifications

Cycle time	Approx 31 seconds
Compaction force:	2.3 tons
Compaction system:	Electro Hydraulic
Safety features:	2 handed synchronous actuation
Safe working area:	3200mm x 2210mm
Machine dimensions:	1660mm W x 1540mm D x 2150mm H
Control panel:	Incorporates full operating instructions, on/off key switch, two button control. Separate selector switch to control direction of compaction plate
Electrical system: (three phase)	24 volt control system. 415 volt 50Hz 3 phase motor
Electrical system: (single phase)	24 volt control system. 240 volt 50Hz single phase motor, 16 amp (commando plug as standard)
Machine weight:	340 kg

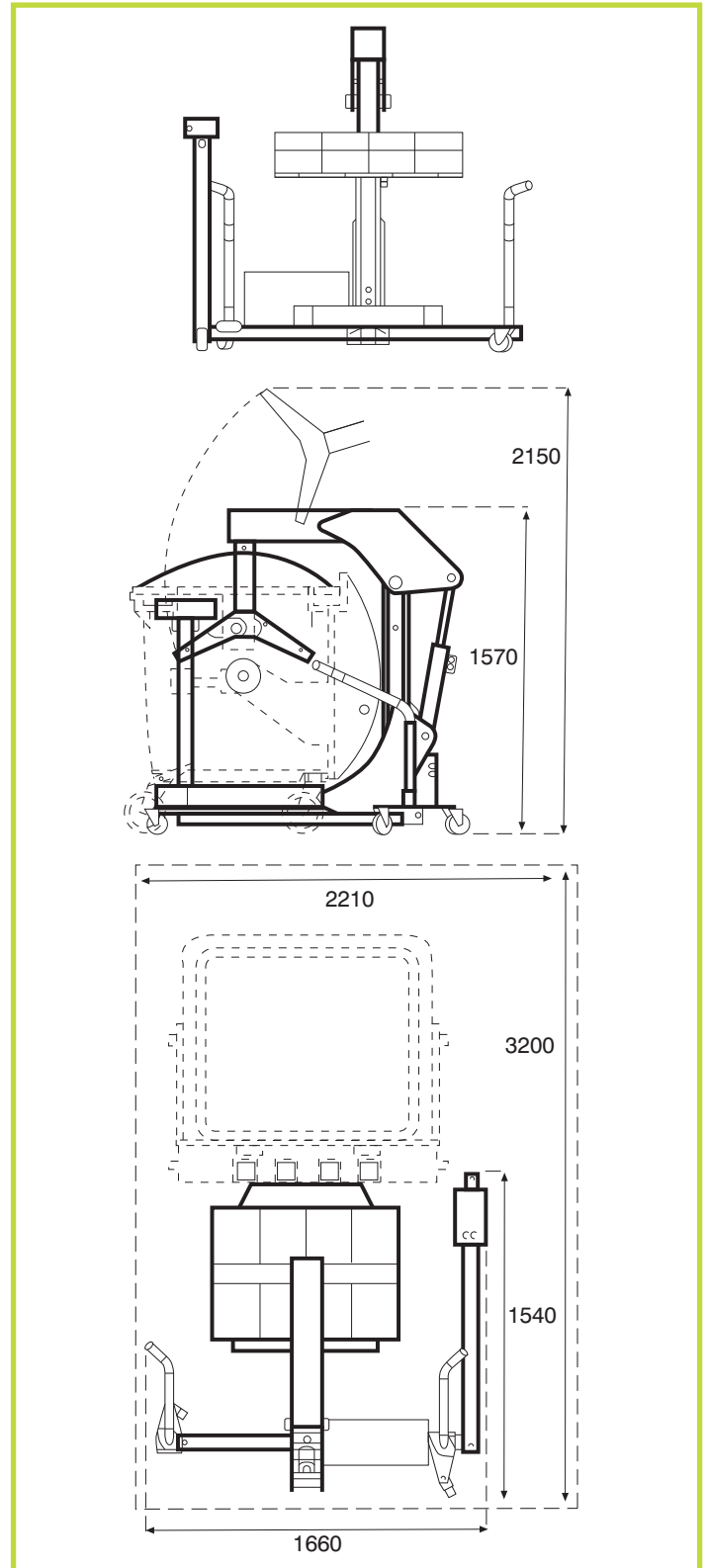

Unit 5, Station Road, Bakewell,
Derbyshire DE45 1GE.
Tel: 01629 813859 Fax: 01629 814334
Email: sales@tonyteam.co.uk
www.tonyteam.co.uk

Total Waste Handling Solutions for a Better Environment



FM 41544

In view of Tony Team's policy of continual improvement, we reserve the right to alter or amend any product specification or detail contained within this brochure.

Expertise and innovation

Tony Team's enviable reputation has been built on excellence of product quality backed-up by the highest levels of customer service. For over 30 years we have been sharpening the leading edge of compactor and baling technology to bring you the most reliable and cost-effective waste management solutions.