

Advanced compaction for a cleaner environment

TT100, TT160, TT180 and TT240 bag compactors

Tony Team bag compactors automatically compress mixed rubbish up to 14% of its original size in seconds, delivering neatly cubed polythene bags that significantly reduce waste volumes.

Constructed from durable and hygienic stainless steel, they handle cardboard, food, paper, cans, waste, packaging, glass and other rubbish; and can be used in conjunction with a Pac-A-Lift for ease of disposal into large bins, or simply a trolley.

Tony Team bag compactors are available in four sizes to match the needs of commercial kitchens, factory production lines, coffee shops, bakeries, sandwich shops, restaurants, fast food outlets, ship and offshore applications.

Key Features

- Simple and safe to use
- Reduce bulk by 85%
- Cut costs by up to 70%
- Electro-hydraulically powered
- Manufactured from food quality stainless steel



Total Waste Handling Solutions
for a Better Environment



Technical Specifications

	TT100	TT160	TT180	TT240
Compaction cycle time:	40 secs	10 secs	22 secs	23 secs
Compaction Pressure:	2,500 kg (2.5 tons)	3,100 kg (3 tons)	4,500Kgs (4.5 tons)	5,000 kg (5 tons)
Compacted package size:	400mm x400mm x 300mm (16" x 16" x 13")	400mm x 400mm x 300mm (16" x 16" x 13")	475mm x 500mm x 475mm (19" x 20" x 19")	500mm x 600mm x 600mm (20" x 24" x 24")
Average weight of compacted package:	14 kg (30 lbs) (4 bags into 1)	16 kg (35 lbs) (6/7 bags into 1)	22 kg (48 lbs) (10/12 bags into 1)	40 kg (90 lbs) (18/20 bags into 1)
Safety features:	Failsafe door switch. Adjustable full load warning system. Package size controls. Reusable bin to contain compacted waste.			
Weight of machine:	150 kg	200 kg	250 kg	300 kg
Motor rating	0.37 kw	0.75 kw	0.75 kw	0.75 kw

Electrical Systems

Supply:	240v 50Hz (3 phase or alternative voltages available if required)
Compaction System:	Twin pressure hydraulic pump powering a single stage hydraulic ram which is aided by a chrome plated guide rod.
Control Panel:	Incorporates full operating instructions, key switch, emergency stop button, start button and full load warning light.
Machine construction:	Stainless steel on mild steel frame with fully welded compaction chamber totally separate from electrical and hydraulic control compartment incorporating an aluminium compaction plate.

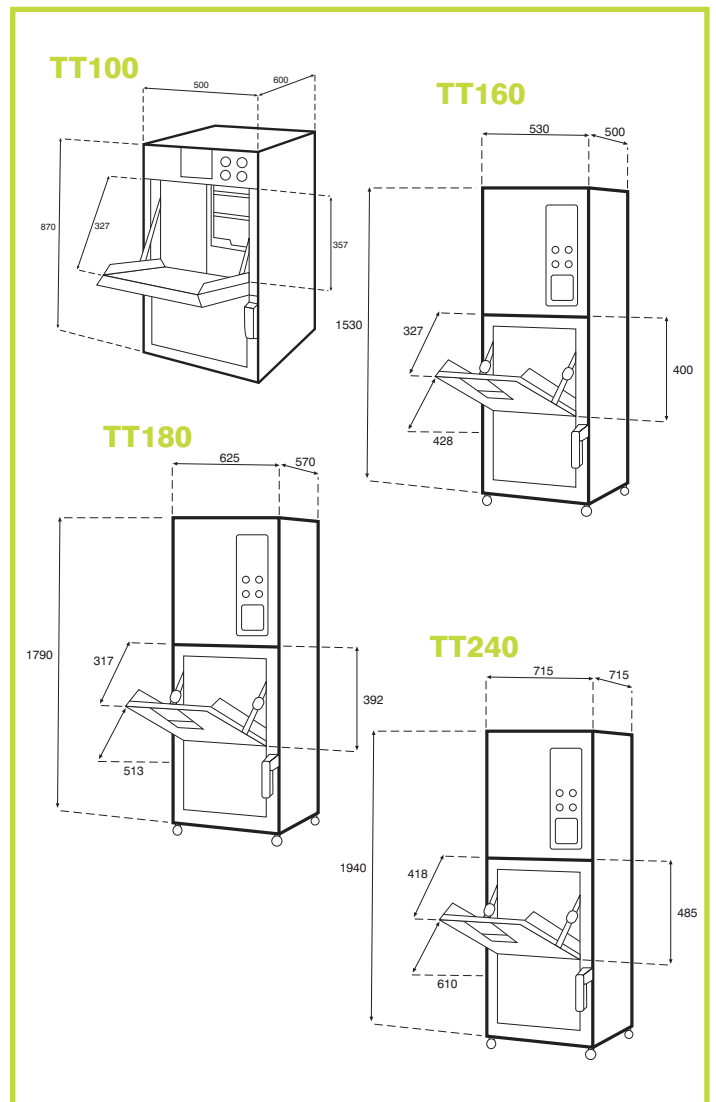

Unit 5, Station Road, Bakewell,
Derbyshire DE45 1GE.
Tel: 01629 813859 Fax: 01629 814334
Email:sales@tonyteam.co.uk
www.tonyteam.co.uk

Total Waste Handling Solutions for a Better Environment



FM 41544

In view of Tony Team's policy of continual improvement, we reserve the right to alter or amend any product specification or detail contained within this brochure.

Expertise and innovation

Tony Team's enviable reputation has been built on excellence of product quality backed-up by the highest levels of customer service. For over 30 years we have been sharpening the leading edge of compactor and baling technology to bring you the most reliable and cost-effective waste management solutions.