

Advanced baling for a better environment

TT45, TT55, TT75 and TT75 multi-chamber small balers

Tony Team balers are simple and easy to use and represent excellent value for money. They provide a cost-effective means of removing card, polythene and other recyclable material from the waste stream and landfill, increasing recycling output and helping to keep waste areas clean and tidy.

The TT45 to TT75 models create bales up to 75 kg making them ideal for pubs, restaurants, hotels, supermarkets, warehouses, hospitals, colleges and fast food outlets. The TT75 multi chamber features twin chambers so that one chamber can be loaded while the other compacts, and different recyclable products such as plastic and cardboard can be compacted simultaneously. Additional chambers are also available.

Key Features

- Small footprint
- Simple and safe to use
- Extremely quiet
- Adjustable bale weight
- Includes lifting trolley



Total Waste Handling Solutions
for a Better Environment



Technical Specifications

	TT45	TT55	TT75	TT75 multi-chamber
Cycle time	Approx 20 seconds	Approx 15 seconds	Approx 24 seconds	Approx 35 seconds
Bale dimensions	550mm H x 535mm W x 450mm D	800mm H x 550mm W x 550mm D	1000mm H x 700mm W x 500mm D	1000mm H x 700mm W x 500mm D
Bale weight	Up to 40kg (dependent on material)	Up to 55kg	Up to 75kg (dependent on material)	Up to 75 kg (dependent on material)
Baler dimensions	1695mm H x 718mm W x 570mm D Transportation height 1695mm	1950mm H x 880mm W x 650mm D Transportation height 1950mm	2350mm H x 1000mm W x 585mm D Transportation height 1800mm	1978mm H x 2050mm W x 820mm D Transportation height 1978mm
Machine weight	140 kg	205 kg	270 kg	562 kg
Pressing force	Up to 2 tonnes	Up to 2 tonnes	Up to 3.5 tonnes	Up to 3.5 tonnes
Loading aperture sizes	535mm H x 430mm W	470mm H x 550mm W	640mm H x 700mm W	700mm W x 500mm D
Power supply	220-240 Volts single phase 16 amp commando plug	220-240 Volts single phase 16 amp commando plug	220-240 Volts single phase 16 amp commando plug	220-240 Volts single phase 16 amp commando plug
Motor	1.5kW	1.5kW	1.5kW	1.5kW
Noise level	72 decibels	72 decibels	72 decibels	72 decibels



TT75 multi-chamber

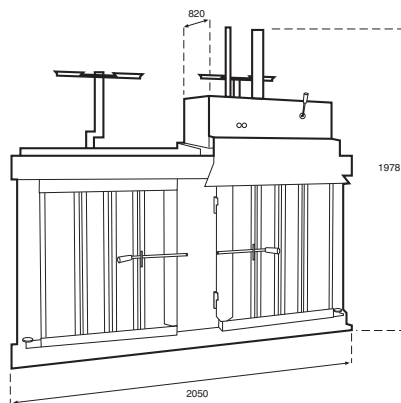

TT75

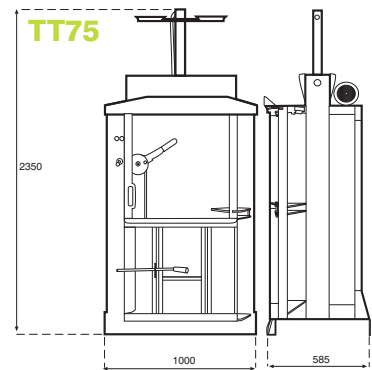

TT55

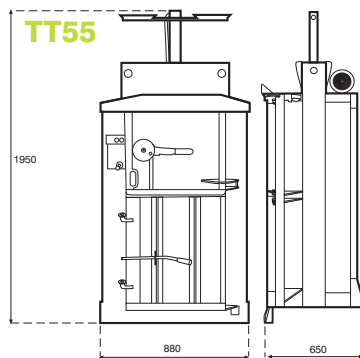

TT45

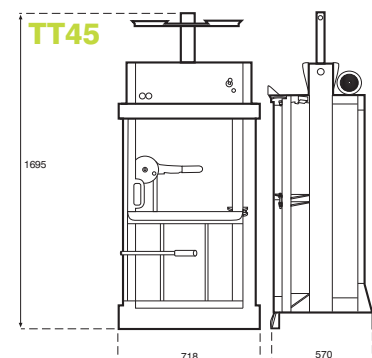

Unit 5, Station Road, Bakewell,
Derbyshire DE45 1GE.
Tel: 01629 813859 Fax: 01629 814334
Email: sales@tonyteam.co.uk
www.tonyteam.co.uk

Expertise and innovation

Tony Team's enviable reputation has been built on excellence of product quality backed-up by the highest levels of customer service. For over 30 years we have been sharpening the leading edge of compactor and baling technology to bring you the most reliable and cost-effective waste management solutions.

Total Waste Handling Solutions for a Better Environment



FM 41544

In view of Tony Team's policy of continual improvement, we reserve the right to alter or amend any product specification or detail contained within this brochure.