

Advanced baling for a better environment

TT150, TT200 multi-chamber and TT250 mid-volume balers

Tony Team balers are simple and easy to use and represent excellent value for money. They provide a cost-effective means of removing card, plastic and other recyclable material from the waste stream and landfill, increasing recycling output and helping to keep waste areas clean and tidy.

The TT150 and TT250 models handle medium volumes of cardboard and polythene, so are ideal for manufacturing and industrial outlets with reasonably high throughput of recyclable material. The TT200 multi-chamber features twin chambers so that one chamber can be loaded while the other compacts, and different recyclable products such as plastic and cardboard can be compacted simultaneously. Additional chambers are available.

Key Features

- Simple and safe to use
- Extremely quiet
- Fully automated bale ejector
- Retaining claws to prevent spring back



Total Waste Handling Solutions
for a Better Environment



Technical Specifications

	TT150	TT200 multi-chamber	TT250
Cycle time	Approx 40 seconds	34 Sec	Approx 34 seconds
Bale dimensions	1000mm H x 950mm W x 800mm D	800mm H x 1100mm W x 800mm D	1000mm H x 1200mm W x 800mm D
Bale weight	Up to 150 kg (dependent on material)	Up to 200 kg (dependent on material)	Up to 250 kg (dependent on material)
Baler dimensions	2800mm H x 1500mm W x 980mm D (Transportation height 2250mm)	2471mm H x 3056mm W x 1105mm D (Transportation height 2471mm)	2780mm H x 1730mm W x 1000mm D (Transportation height 2250mm)
Weight	780 kg	1400 kg	985 kg
Pressing force	Up to 8 tonnes	Up to 15 tonnes	Up to 15 tonnes
Loading aperture sizes	650mm H x 950mm W	1100mm W x 800mm D	660mm H x 1200mm W
Power supply	220-240 Volts single phase 20 Amp C rated MCB	220-240 Volts single phase 20 Amp C rated MCB	220-240 Volts single phase 20 Amp C rated MCB
Motor	2.2kW	2.2kW	2.2kW
Noise level	74 decibels	72 decibels	74 decibels

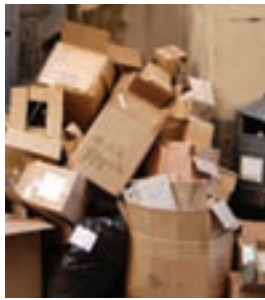

TT150

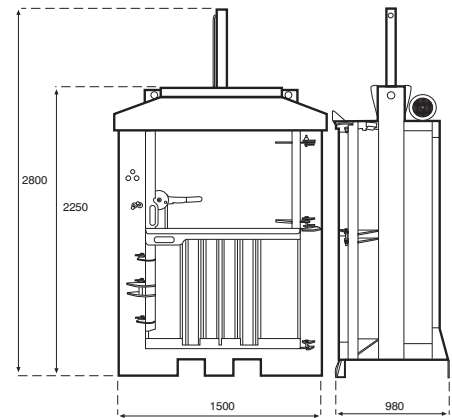

TT200 multi-chamber

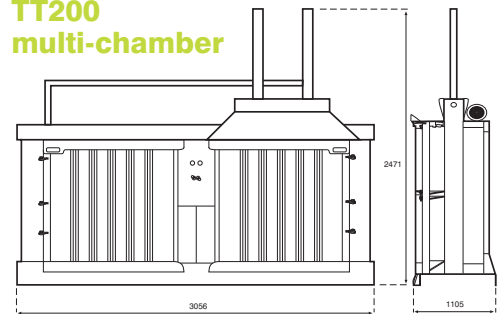

TT250

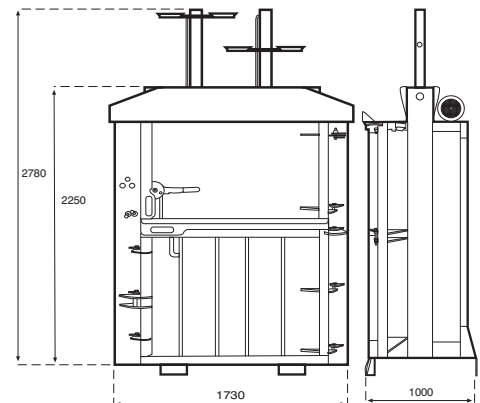

Unit 5, Station Road, Bakewell,
Derbyshire DE45 1GE.
Tel: 01629 813859 Fax: 01629 814334
Email: sales@tonyteam.co.uk
www.tonyteam.co.uk

Expertise and innovation

Tony Team's enviable reputation has been built on excellence of product quality backed-up by the highest levels of customer service. For over 30 years we have been sharpening the leading edge of compactor and baling technology to bring you the most reliable and cost-effective waste management solutions.

Total Waste Handling Solutions for a Better Environment



FM 41544

In view of Tony Team's policy of continual improvement, we reserve the right to alter or amend any product specification or detail contained within this brochure.